

B&T MP9

BT-30104

OPERATOR'S MANUAL



Brügger & Thomet AG
P.O. Box 42 • 3608 Thun
Switzerland
Fon +41 33 334 67 00
Fax +41 33 334 67 01
info@brugger-thomet.ch
www.brugger-thomet.ch



TM-95107.00

TABLE OF CONTENTS

SAFETY INSTRUCTIONS	5
NOMENCLATURE	6
UPPER RECEIVER	6
LOWER RECEIVER	6
LEFT SIDE	7
RIGHT SIDE	8
TECHNICAL DATA	9
HANDLING AND OPERATOR PROCEDURES	10
MAKING THE WEAPON SAFE	10
MAGAZINE LOADING AND UNLOADING	11
OPERATION OF THE BOLT RELEASE LEVER	12
LOADING THE WEAPON	13
UNLOADING THE WEAPON	14
CHANGING MAGAZINES	14
RELOADING THE WEAPON	15
SAFETY AND FIRE SELECTION	15
OPERATION OF THE FOLDING STOCK	16
FIRING POSITION	17
SIGHT ADJUSTMENT	18
BASIC DISASSEMBLY, CLEANING AND ASSEMBLY	19
FIELD DISASSEMBLY AND MAINTENANCE	19
FULL DISASSEMBLY AND LUBRICATION	22
FUNCTION CHECK	24
MALFUNCTIONS AND IMMEDIATE ACTION	25
MALFUNCTION 1	25
MALFUNCTION 2	25

TABLE OF CONTENTS

ACCESSORIES	26
STANDARD DELIVERY	26
AIMPOINT REFLEX SIGHT	27
ADAPTOR LIGHT LASER	28
TOP COVER WITH SIDE RAILS	29
SOUND SUPPRESSOR	30
BRASS CATCHER	31
DUTY HOLSTER	32
HIGH RIDE HOLSTER	33
TACTICAL HOLSTER	34
SPARE PARTS	35
EXPLODED DRAWING	37
NOTES	38
MANUFACTURERS WARRANTY INFORMATION	40
THE MANUFACTURER	40

SAFETY INSTRUCTIONS

- Every weapon must be considered loaded, until verified individually by the operator as outlined in paragraph 'Making the Weapon safe'.
- Always keep the finger off the trigger and outside the trigger guard, it is advised to keep the trigger finger along side of the housing except when ready to fire.
- Always point the weapon in a safe direction.
- Before firing always verify the serviceability and condition of both the weapon and ammunition. Be especially careful that the barrel is free from all obstructions.
- Always wear hearing and eye protection when using this or any weapon.

This operator's manual is supplied with each weapon.

NOMENCLATURE

UPPER RECEIVER

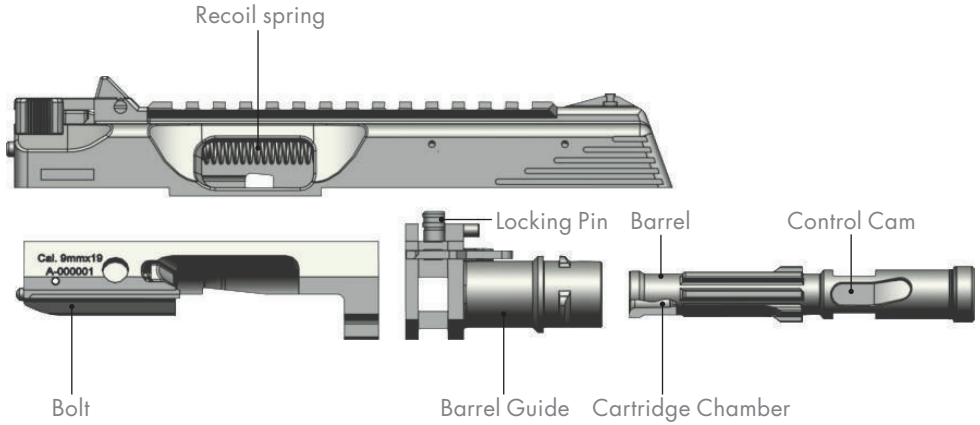

LOWER RECEIVER

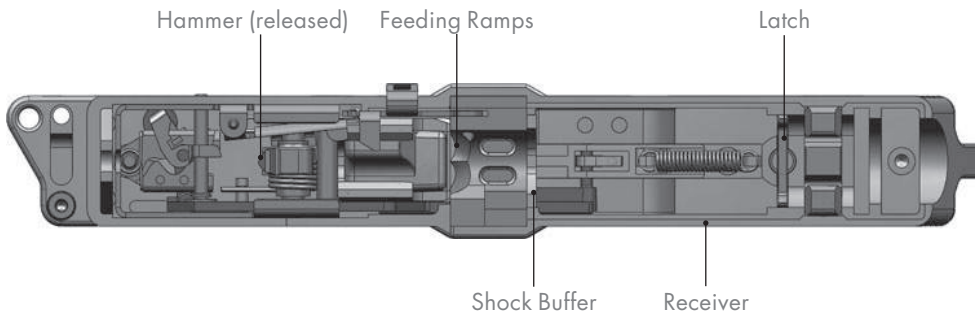

NOMENCLATURE

LEFT SIDE

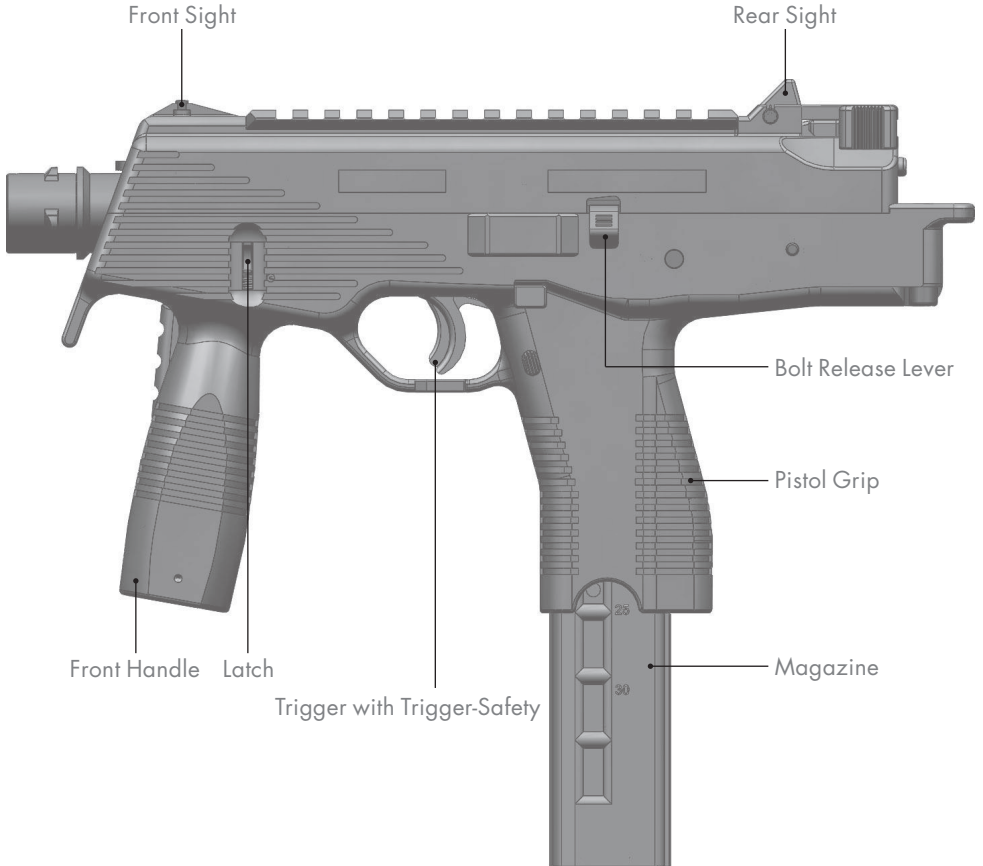

NOMENCLATURE

RIGHT SIDE

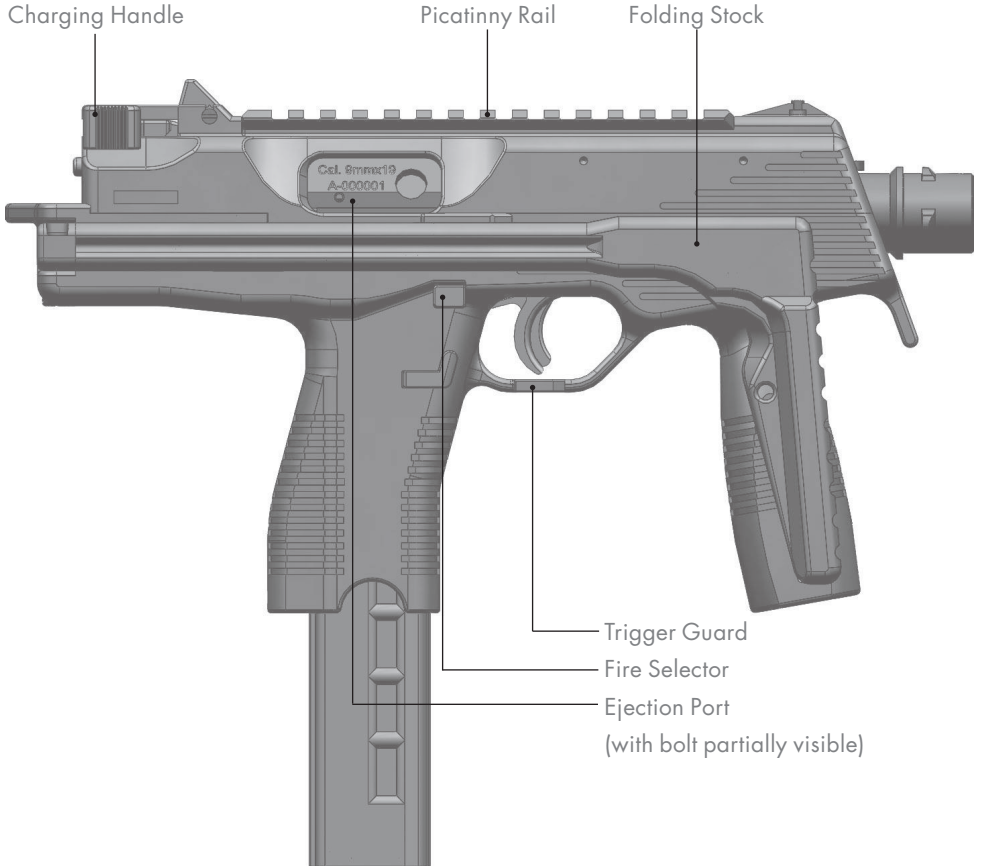

TECHNICAL DATA

Function:	Rotating Barrel Locking System
	Locked Closed Bolt Action
	Bolt remains open after last Shot
Safety System:	Double Trigger Safety
	Drop Safety
Firing Modes:	Semi-Automatic
9 mm Ballistics:	360 m/sec (NATO 124 g)
	520 Joule
Magazines:	15, 20, 25 and 30 Cartridges
	High-strength, translucent Polymer
Sighting System:	Square Notch Pistol Sight, fully adjustable
	MIL-STD 1913 Picatinny Rail
Length:	523 mm (stock fold out)
	303 mm (stock closed)
Height:	166 mm
	173 mm (with 15 round Magazine)
	246 mm (with 30 round Magazine)
Width:	45 mm (stock fold out)
	56 mm (stock closed)
Barrel Length:	130 mm
Weight:	1.4 kg without Magazine
Magazine Weight:	150 g / 10 Cartridges loaded (NATO 124 g)
	240 g / 15 Cartridges loaded (NATO 124 g)
	440 g / 30 Cartridges loaded (NATO 124 g)
Colours:	Black, Green, Coyote Tan

HANDLING AND OPERATOR PROCEDURES

MAKING THE WEAPON SAFE

To ensure that the weapon is safe

- 1) Press the magazine release and pull the magazine downward from the pistol grip.
- 2) Pull the charging handle completely to the rear and inspect that no cartridge is in the barrel (cartridge chamber).

To verify that the weapon is loaded

- 1) Pull the charging handle just far enough back so that a loaded cartridge can be viewed in the ejection port (Fig. 1.1).



Fig. 1.1

HANDLING AND OPERATOR PROCEDURES

MAGAZINE LOADING AND UNLOADING

Loading the Magazine

- 1) While holding the magazine in one hand, press the cartridge into the magazine follower with the thumb of the other hand until the cartridge is held in place by the lips of the magazine.
- 2) Repeat the procedure until the magazine is full. The top cartridge should be positioned on the right side of the magazine (Fig. 1.2).

Unloading the Magazine

- 1) Press the base of the lower cartridge with the multi-purpose tool supplied in cleaning kit until the upper cartridge drops out (Fig. 1.3).
- 2) Repeat the procedure one after another individually until the magazine is empty.
- 3) Allow the cartridges to fall on a soft surface and be inspected before further use.

Tip: Operation can be ensured if the 30 round magazines is loaded with 29 cartridges and the 20 round magazine with 19 cartridges!



Fig. 1.2



Fig. 1.3

HANDLING AND OPERATOR PROCEDURES

OPERATION OF THE BOLT RELEASE LEVER

To keep the bolt in the open position

- 1) Remove the magazine.
- 2) Pull the charging handle to its rear most position (Fig. 1.4).
- 3) Press the bolt release lever upward.
- 4) Leave the bolt slide forward, until it is held in place by the bolt release lever.
- 5) Return the charging handle into original position.

To close the bolt

- 1) Press the bolt release lever downward, until the bolt rides forward.

Caution: Keep away the fingers from the ejection port when pressing the bolt release lever downward!



HANDLING AND OPERATOR PROCEDURES

LOADING THE WEAPON

When the bolt is in the closed position

- 1) Slide the loaded magazine into the pistol grip until an audible click is heard (Fig. 1.5).
- 2) Verify the magazine is well seated by slightly pulling downward on the magazine.
- 3) Vigorously pull back the charging handle and let it slide forward under its own power.
- 4) Verify weapon is loaded as outlined in paragraph 3 of "Making the Weapon safe".

When the bolt is in the opened position

- 1) Insert a loaded magazine into the pistol grip until there is an audible click.
- 2) Pull the magazine slightly downward to verify it is well seated.
- 3) Vigorously pull back the charging handle and let it slide forward under its own power (Fig. 1.6).
- 4) Verify weapon is loaded as in paragraph 3 of 'Making the Weapon safe'.

During this procedure the finger is to be kept **off** the trigger. It is advised for the finger to be placed along the side of the weapon. The weapon is now loaded, the safety on and ready to fire.



Fig. 1.5



Fig. 1.6

HANDLING AND OPERATOR PROCEDURES

UNLOADING THE WEAPON

- 1) Press the magazine release with the thumb of the right hand. Pull the magazine down and out of the weapon.
- 2) Pull back the charging handle vigorously so that the cartridge is ejected from of the barrel.
- 3) Visually verify that there is not a cartridge still left in the chamber.
- 4) Ride the bolt forward with the charging handle.
- 5) Recover the loose cartridge.
- 6) Point the weapon into a safe direction and pull the trigger – the hammer strikes audibly.

During this procedure the finger is to be kept **off** the trigger. It is advised for the finger to be placed along the side of the weapon. By now the weapon is unloaded, uncocked and the safety is engaged.

CHANGING MAGAZINES

- 1) A magazine change takes place when the weapon is loaded with a cartridge in the barrel.
- 2) Press magazine release button and grasp the magazine and pull downward from the pistol grip.
- 3) Insert a fully loaded magazine into the pistol grip until there an audible sound of the magazine release engaging.
- 4) Verify that the magazine is well seated by slightly pulling downward on the magazine.

HANDLING AND OPERATOR PROCEDURES

RELOADING THE WEAPON

- 1) Reloading takes place when a weapon is fired until empty - the bolt is therefore held open by the bolt release.
- 2) Grasp the magazine and press the magazine release. While at the same time pull the magazine sharply from the pistol grip.
- 3) Insert a fully loaded magazine into the pistol grip until there is an audible sound of the magazine release engaging.
- 4) Verify that the magazine is properly seated by slightly pulling downward on the magazine.
- 5) Vigorously pull back the charging handle and let it slide forward under its own power.

SAFETY AND FIRE SELECTION

- 1) The weapon safety is integrated into the trigger. The safety is disengaged only immediately before the trigger is pressed and a round is fired.
- 2) The fire selector switch has only two positions „semi-automatic“ and „fully-automatic“.
- 3) The operator slides the fire selector as illustrated onto either of the two positions marked by a pictogram: 1 point for single-shot fire (Fig. 1.7) and 3 points for fully-automatic fire (Fig. 1.8)
- 4) The operator selects which mode of fire is to be used by pressing either end of the selector until it engages in the desired position.
- 5) For the right handed and left handed shooters, different fire selector options are available. This is to ensure a uniform procedure of operation for either the right or left handed shooter: Pressure on the fire selector with the trigger finger selects single-shot fire, pressure with the thumb of the firing hand selects fully automatic fire.



HANDLING AND OPERATOR PROCEDURES

OPERATION OF THE FOLDING STOCK

Opening of the folding stock

- 1) Hold the weapon with the shooting hand at the pistol grip.
- 2) With the opposite hand take the folding stock and with a firm action pull it from its folded locked position (Fig. 1.9).
- 3) Swing the folding stock, until it is locked in the extended position.
- 4) Verify that the stock is fully seated in the locked position.

Closing of the folding stock

- 5) Hold weapon with the shooting hand at the pistol grip.
- 6) With the opposite hand hold the folding stock and press locking device button at the end of the receiver strongly upward (Fig. 1.10).
- 7) Rotate the folding stock, until it locks into its front position.
- 8) Verify that the stock is securely seated onto the weapon.

Fig. 1.9



Fig. 1.10



HANDLING AND OPERATOR PROCEDURES

FIRING POSITION

- 1) The weapon is fired with both hands; the firing hand is on the pistol grip and the support hand on the front handle. Keep the support hand on the vertical hand grip to avoid injury by accidentally being placed in front of the muzzle!
- 2) Place the trigger finger of the firing hand on the trigger and smoothly press to insure an accurate shot.



Fig. 1.11

HANDLING AND OPERATOR PROCEDURES

SIGHT ADJUSTMENT

Left and Right Corrections

- 1) To zero shots to the right or left of the point of aim is made by the adjustment screw at the right side of the rear sight with a No. 1 screwdriver (Fig. 1.12).
- 2) One full turn of the sight adjustment screw in a clockwise direction changes the point of impact around 165 mm on 25 m to the left - therefore turn in the clockwise direction when point of impact is right off.

Up and Down Corrections

- 1) To zero shots above and below the point of aim disassemble the weapon as outlined in paragraph 'Field Disassembly and Maintenance'.
- 2) The zeroing of a shot above or below of the point of aim is done by the adjustment screw on the inner side of the upper housing group with a No. 0 screwdriver (Fig. 1.13).
- 3) One full turn of the adjustment screw in a clockwise direction changes the point of impact about 90 mm on 25 m downward – therefore turn in a clockwise direction for a high shot.
- 4) After performing out this correction reassemble the weapon in accordance with paragraphs 3-6 of 'Field Reassembly' and check function as in paragraph 'Function Check'.



Fig. 1.12



Fig. 1.13

BASIC DISASSEMBLY, CLEANING AND ASSEMBLY

FIELD DISASSEMBLY AND MAINTENANCE

Field Disassembly

- 1) Unload the weapon - the weapon is now unloaded and cocked.
- 2) Press the latch downward and slide the bolt into foremost position (Fig. 2.1).
- 3) Press the guide rod and gently lift the top cover on (Fig. 2.2).
- 4) Press the detent plate and remove top cover with barrel assembly upward in a straight movement without canting (Fig. 2.3).
- 5) With light pressure push the bolt and barrel assembly to the rear of the top cover and lift them out (Fig. 2.4).
- 6) Hold barrel assembly and slowly separate from the bolt, until barrel and bolt are in two pieces.

Now the top cover, the receiver, the barrel assembly and the bolt are separated and ready for cleaning.



BASIC DISASSEMBLY, CLEANING AND ASSEMBLY

Field Cleaning

- 1) Screw the small copper brush on to the flex rod tip and lightly oil. Screw eyehole on other end of the flex rod.
- 2) Push the eyehole through the barrel from the chamber and attach the handle, pull copper brush through the barrel (Fig. 2.6). Repeat until barrel is clean.
- 3) Separate the barrel and bolt from the barrel guide. Clean the inside of the barrel guide with multipurpose tool and copper brush supplied in the maintenance kit. In the case of strong carbon build up first oil the parts and scrape off the excess fouling (Fig. 2.6). Wipe all surfaces with oily rag.
- 4) Clean carbon off the bolt with a copper brush. Wipe all metal surfaces with oily rag.
- 5) Separate the recoil spring from the guide rod and wipe with an oily rag.
- 6) Wipe the feeding ramp completely free of dirt with an oily rag.
- 7) Brush with a nylon brush all exposed surfaces and pay particular attention to the sights to ensure these are free of dirt.



Fig. 2.6

BASIC DISASSEMBLY, CLEANING AND ASSEMBLY

Field Reassembly

- 1) Install the recoil spring and the guide rod.
- 2) Push the barrel into the bolt.
- 3) Thread the bolt onto the recoil spring, to the rear and press the detent plate into position (reversal of 4 of paragraph 'Field Disassembly').
- 4) Put assembled top cover in a straight line motion on the receiver (reversal of 3 of paragraph 'Field Disassembly'). If not possible check hammer to be cocked. Caution: The hammer must be cocked and the locking sear in its most left position as shown in Fig. 2.7!
- 5) Pull the bolt to the charging handle lightly to the rear, until plate moves into the upper position.
- 6) Perform function check in accordance with paragraph 'Function Check'.

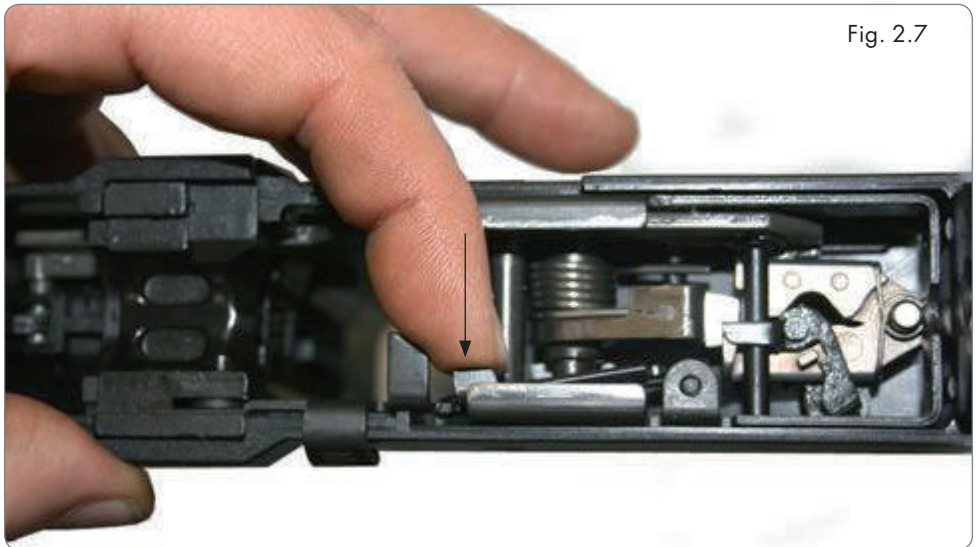

Fig. 2.7

BASIC DISASSEMBLY, CLEANING AND ASSEMBLY

FULL DISASSEMBLY AND LUBRICATION

Caution: The full disassembly releases the locking pin – loosing it makes the weapon useless!

Full Disassembly

- 1) Follow the steps in accordance with section 'Field Disassembly'.
- 2) Push the detent plate with the multi-purpose tool and pull the locking pin upward from the barrel guide (Fig. 2.8).
- 3) Draw the barrel forward from the barrel guide.
- 4) Pull and separate the recoil spring and guide rod from the top cover.
- 5) Draw back the charging handle to the rear and separate it from the top cover.

Full Maintenance

- 1) Clean the barrel in accordance with 1-2 of 'Field Cleaning'.
- 2) Clean thoroughly the carbon from the inside of the barrel guide with the multi-purpose tool (Fig. 2.9). Apply oil to the areas of strong build up to break down the carbon.
- 3) Wipe all metal surfaces with an oily rag.
- 4) Inspect all visible surfaces for crack or defect and clean with a nylon brush clean.
- 5) Apply one drop of oil to the designated individual points (Fig. 2.10 & 2.11).

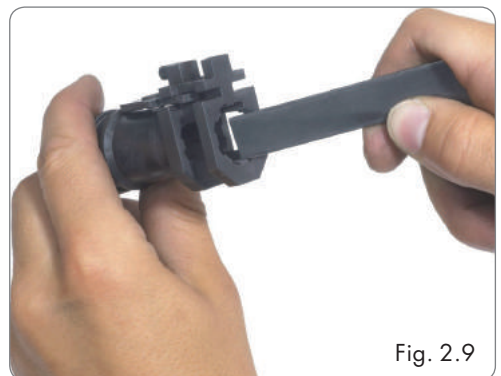

BASIC DISASSEMBLY, CLEANING AND ASSEMBLY

Full Reassembly

- 1) Insert the barrel into the front of barrel guide in such a way that the locking pin can engage the control cam.
- 2) Push the detent plate with the multi-purpose tool and slide forward the locking pin with the flattened side up (groove to the left). Align the barrel in such a way with the free hand that the locking pin fits into the control cam (see fig. 2.12).
- 3) Insert the charging handle.
- 4) Assemble the guide rod and recoil spring.
- 5) Continue on as outlined in accordance with 1-6 of paragraph 'Field Reassembly'.

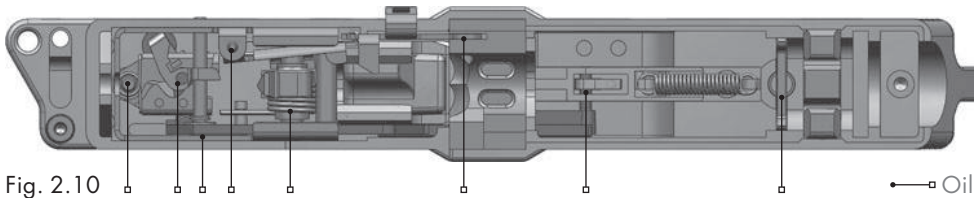

Fig. 2.10

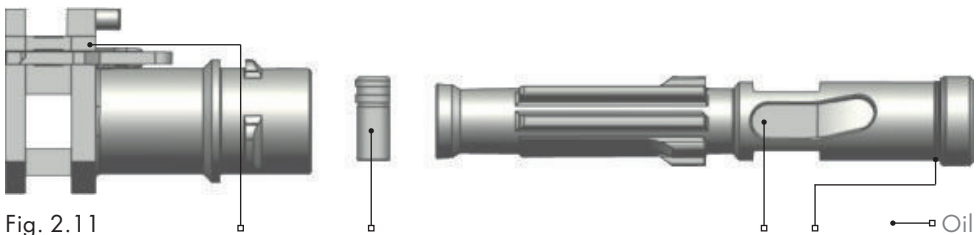

Fig. 2.11

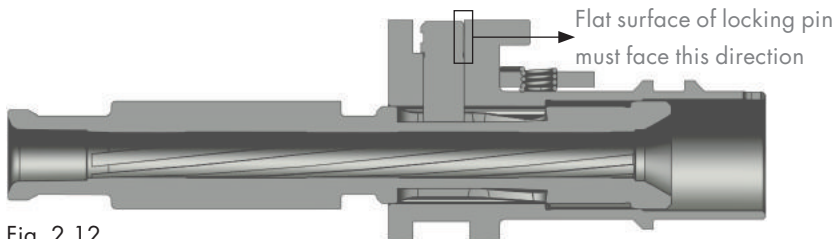

Fig. 2.12

BASIC DISASSEMBLY, CLEANING AND ASSEMBLY

FUNCTION CHECK

Caution: Make the weapon safe before executing procedure!

- 1) Insert an empty magazine and pull downward - the magazine release must hold securely.
- 2) Leave the empty magazine in the gun, pull the charging handle to the very rear and release ⇒ bolt release lever must hold the bolt open.
- 3) Remove magazine and press bolt release ⇒ bolt must ride forward.

Steps 1-3 must be performed with each individual magazine.

- 4) Place fire selector switch on single-shot and press the trigger ⇒ hammer must audibly strike.
- 5) Keep the trigger pressed, pull the charging handle completely to the rear and slowly return it to the forward position. Release the trigger and press ⇒ hammer again must audibly strike.
- 6) Move fire selector to the fully automatic position, pull the charging handle to the rear and slowly return it to the forward position. Press the trigger ⇒ hammer must audibly strike.
- 7) Keep the trigger pressed, pull the charging handle to the rear and slowly return it to the forward position ⇒ hammer must audibly strike, as soon as the bolt reaches the foremost position.
- 8) Check sighting devices.

MALFUNCTIONS AND IMMEDIATE ACTION

MALFUNCTION 1

Hammer strike does not fire a shot. Measures:

- 1) Strike the bottom of the magazine with the palm of the support hand.
- 2) Pull the charging handle completely to the rear to and let it ride forward.
- 3) Inspect ejected cartridge later.

MALFUNCTION 2

Pressing the trigger does not make strike the hammer. Measures:

- 1) Remove the magazine and inspect it individually later.
- 2) Pull the charging handle to the rear and verify that there are no more cartridges and/or cases in the chamber.
- 3) Insert a fresh magazine into the pistol grip until hearing the sound of the magazine release engaging.
- 4) Pull the magazine downward to assure it is firmly seated.
- 5) Pull the charging handle to the rear and allow the bolt to slam forward under its own power.

Note: Heavy carbon build up can induce the bolt can jam shut. By means of placing a case or cartridge in the small round hole in the bolt can it be forced open again as illustrated below (Fig. 3.1).



ACCESSORIES

STANDARD DELIVERY

Standard delivery includes:

- Weapon
- 15 rds magazine
- 30 rds magazine
- Carrying sling
- Cleaning kit
- Hard-top case
- Operator's manual



ACCESSORIES

AIMPOINT REFLEX SIGHT

Performance:

- Fast and sure target acquisition.
- Doubles hit probability.
- Compatible with night vision devices.

Sight-in distance: 15 m recommended

Point-Blank-Range: 2 m to 100 m (for target dia. 100 mm)

Operation and maintenance: Refer to manufacturer manuals.



ACCESSORIES

ADAPTOR LIGHT LASER

Performance:

- Provides additional interface for IT M3, M6 and similar laser light modules.
- Reduces muzzle flip as secondary effect.

Part number: BT-30120



ACCESSORIES

TOP COVER WITH SIDE RAILS

Performance:

- Feature Picatinny MIL-STD 1913 rail on right side or both left and right side.
- Complete with iron sights.

Part number: BT-30300 (right side rail) / BT-30358 (right and left side rail)



ACCESSORIES

SOUND SUPPRESSOR

Performance:

- Reduces muzzle flash.
- Attachment for under barrel laser/light module.
- Sound reduction:

Ammunition	without suppressor	with suppressor	Sound reduction
9mm x 19 Standard	163.3 dB A	130.1 dB A	33.2 dB A
9mm x 19 Subsonic	158.7 dB A	125.1 dB A	33.6 dB A

Part number: SD-988401



ACCESSORIES

BRASS CATCHER

Performance:

- Attaches to side rail top covers.
- Recommended in sensitive environment such as vehicles or helicopters.

Part number: BT-30392



ACCESSORIES

DUTY HOLSTER

Part number: BT-30339R (right hand) / BT-30339L (left hand)



ACCESSORIES

HIGH RIDE HOLSTER

Part number: BT-30341R (right hand) / BT-30341L (left hand)



ACCESSORIES

TACTICAL HOLSTER

Part number: BT-30332R (right hand) / BT-30332L (left hand)



SPARE PARTS

Parts:

Pos.	Designation	Part No.	Pos.	Designation	Part No.
1	Receiver (Empty)	BT-30224	28	Control Lever	BT-30176
2	Firing Pin	BT-30113	29	Magazine Plate	BT-30177
3	Stock Axis	BT-30116	30	Magazine Follower	BT-30178
4	Detent Plate	BT-30126	31	Magazine Body 30 rds	BT-30180
5	Locking Pin	BT-30127	32	Locking Device Button	BT-30184
6	Axle Pin	BT-30128	33	Locking Bar	BT-30185
7	Trigger Pin	BT-30132	34	Locking Lever	BT-30191
8	Roller	BT-30133	35	Trigger Housing	BT-30192
9	Buffer	BT-30134	36	Bolt Release Lever	BT-30193
10	Magazine Release	BT-30136	37	Drop Safety	BT-30194
11	Sear	BT-30141	38	Shock Buffer	BT-30195
12	Sear Bar	BT-30146	39	Extractor Spring	BT-30198
13	Fire Selector	BT-30147	40	Clevis Pin	BT-30199
14	Latch	BT-30148	41	Ramp	BT-30203
15	Front Sight	BT-30149	42	Magazine Spring	BT-30205
16	Charging Handle	BT-30150	43	Sear Spring	BT-30210
17	Adjusting Screw	BT-30151	44	Hammer Spring	BT-30218
18	Connector	BT-30155	45	Bolt Release Lever Spring	BT-30219
19	Guide Rod	BT-30156	46	Barrel	BT-30226
20	Disconnecter	BT-30159	47	Barrel Guide	BT-30227
21	Trigger	BT-30163	48	Rear Sight	BT-30229
22	Follower Spring	BT-30164	49	Bolt	BT-30230
23	Extractor Plunger	BT-30165	50	Folding Stock	BT-30234
24	Extractor	BT-30167	51	Top Cover	BT-30235
25	Rear Sight Spring	BT-30168	52	Trigger Safety	BT-30265
26	Detent Plate Spring	BT-30169	53	Washer Lock $\varnothing 4$	BT-30267
27		BT-30173	54	Trigger Spring	BT-30268

SPARE PARTS

Parts:

Pos.	Designation	Part No.	Pos.	Designation	Part No.
55	Recoil Spring	BT-30269	60	Washer Lock ø3.2	BN809-2.3
56	Magazine Release Spring	BT-30270	61	Trigger Safety Spring	38/2/1
57	Spiral Pin ø4x8	BT-30275	62	Drop Safety Spring	38/2/2
58	Spiral Pin ø3x20	BT-30276	63	Latch Spring	53/4/2
59	Firing Pin Spring	BT-30277	64	Locking Device Button Spring	54/3/3

Assemblies:

Components by Position	Designation	Assy No.
4 & 5 & 26 & 47	Barrel Guide Complete	BT-30293
2 & 18 & 23 & 24 & 38 & 39 & 49 & 58 & 59	Bolt Complete	BT-30231
15 & 16 & 25 & 48 & 51	Top Cover Complete	BT-30336
17 & 25 & 48	Rear Sight Complete	BT-30223
24 & 38 & 39	Extractor Complete	BT-30357
Without Magazine	Receiver Complete	BT-30284

EXPLODED DRAWING

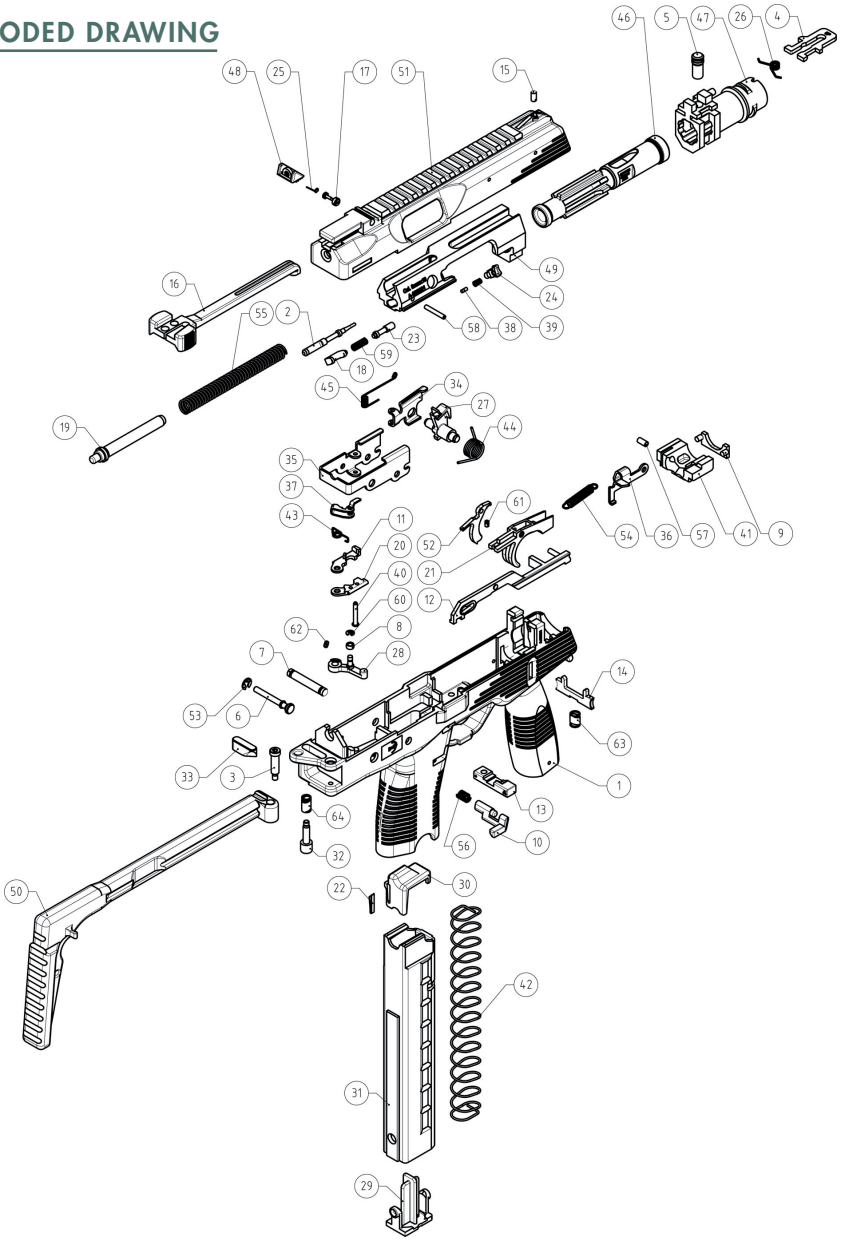

MANUFACTURERS WARRANTY INFORMATION

The manufacturer guarantees this product to be free from all defects of material or workmanship. This warranty is valid only under the following circumstances:

- Properly tested and produced factory cartridges are fired from the weapon.
- Repairs are made by properly trained technical personnel.
- All care and maintenance instructions recommended by the factory are followed.

When ordering spare parts please refer to section 'Spare Parts' of this manual and order by part number. Please also indicate the serial number of the weapon and invoice number in which it was supplied by the factory.

Technical specifications may be subject to modifications. The shown pictures may not correspond to your weapon in each detail.

THE MANUFACTURER

Brügger & Thomet AG
P.O. Box 42 • 3608 Thun
Switzerland
Fon +41 33 334 67 00
Fax +41 33 334 67 01
info@brugger-thomet.ch
www.brugger-thomet.ch