



B&T BWC9-320 CHASSIS

BT-430298

OPERATOR MANUAL



B&T AG
3608 Thun • Switzerland
Fon +41 33 334 67 00
info@bt-ag.ch
www.bt-ag.ch

TM-430298_BWC9-00-EN

Table of content

1. General rules	4
1.1 General Firearm safety rules	4
1.2 BWC9-320 Chassis Safety rules	4
2. Nomenclature.....	6
3. Technical data	7
4. Installation procedures	8
4.1 Required tools	8
4.2 Installation.....	8
5. Usage.....	14
5.1 Folding	14
5.2 Unfolding	15
6. Maintenance & Troubleshooting.....	16
7. Warranty statement	17
8. Manufacturer's Disclaimer	17

Legal Advice



The assembly of a weapon may not be legal in your country or state. Always check the laws to ensure you are legally able to own and/or assemble in your location. In the United States all NFA rules apply.

Compatibility Advice



The BWC9-320 chassis is designed for standard and compact size SIG® P320 pistols with original fire control unit (FCU).

Compatibility Advice



The BWC9-320 chassis is designed to be compact. Therefore slides with iron sights higher than factory sights will not fit the BWC. Check that your sights meet these specifications before installation.

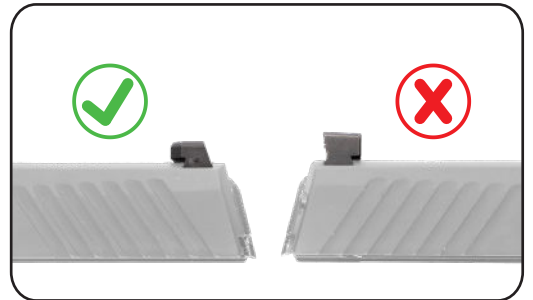

Compatibility Advice



The BWC9-320 chassis is designed to work with factory 19 & 21 round SIG magazines. 15 round magazines are too short and will not seat. Check that your magazines meet these specifications before installation.

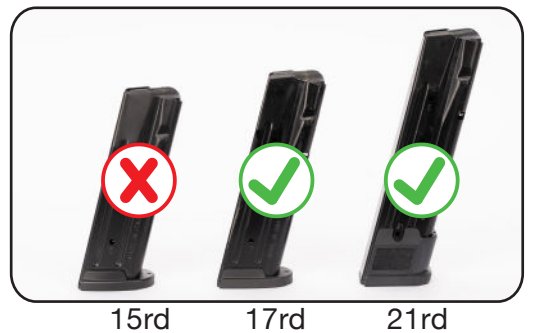

Advice



The weapon, the chassis and the accessories shown here may not be identical with your weapon, chassis or accessories. However, the installation is analogous.

1. General rules

READ MANUAL BEFORE USE.

1.1 General Firearm safety rules

1. Consider every weapon loaded until checked personally by the individual operator.
2. Always keep fingers off the trigger and outside the trigger guard until the sights are on target.
3. Always point the weapon in a safe direction.
4. Verify your target and the backstop.
5. Before firing always verify the serviceability and condition of both the weapon and ammunition.
6. Hearing and eye protection are mandatory.
7. Be sure to use NATO, SAAMI or CIP certified cartridges of correct caliber only.
8. If a cartridge fails to ignite, keep the muzzle pointed in a safe direction and open the chamber only after a minimum of 30 seconds.
9. Live fire training should be carried out in open or well-ventilated areas to prevent excessive exposure to toxic gases.
10. Operate your weapon consciously and do not use excessive force.

1.2 BWC9-320 Chassis Safety rules

1. User installation or removal of the chassis must be carried out in accordance with the instructions contained in this manual.
2. Serious injury to the user may result from an improperly installed chassis.
3. Never fold the chassis system with a live round in the chamber.

SAFETY ADVICE



Never fold the chassis system with a live round in the chamber.

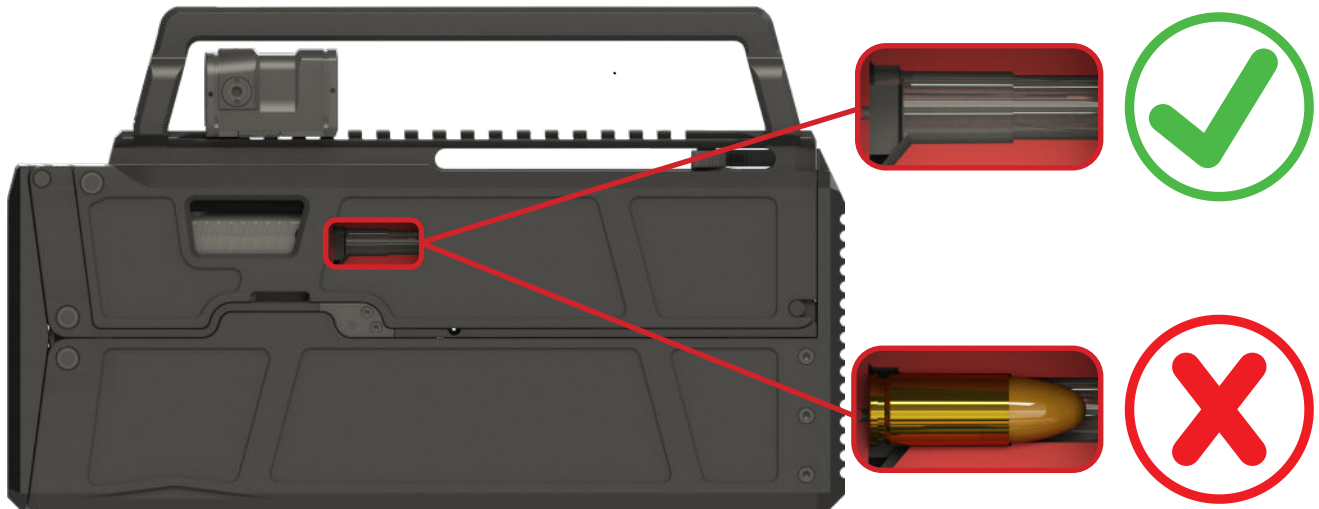

SAFETY ADVICE



Never grip the gun past the hand stop to avoid reaching in front of the muzzle.



2. Nomenclature

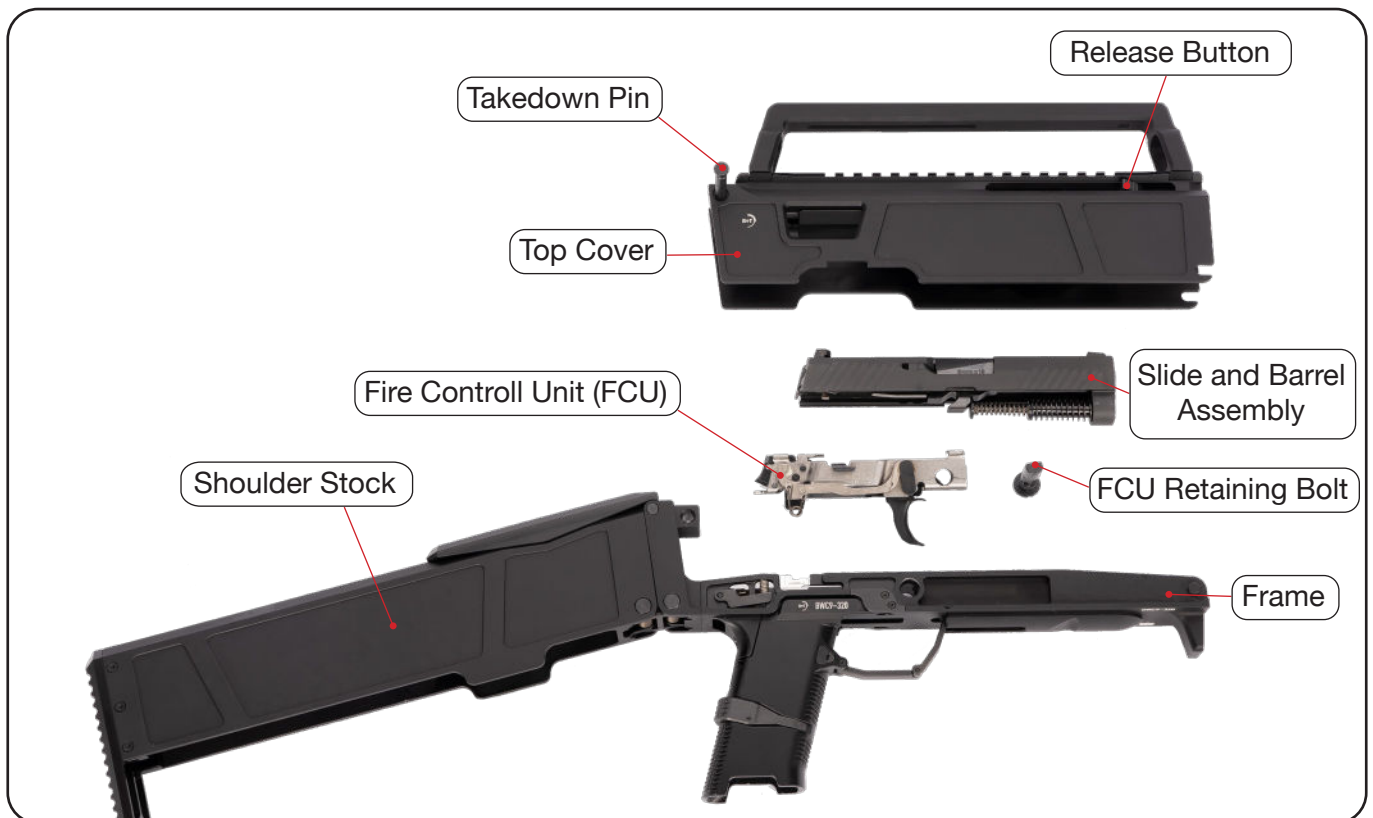
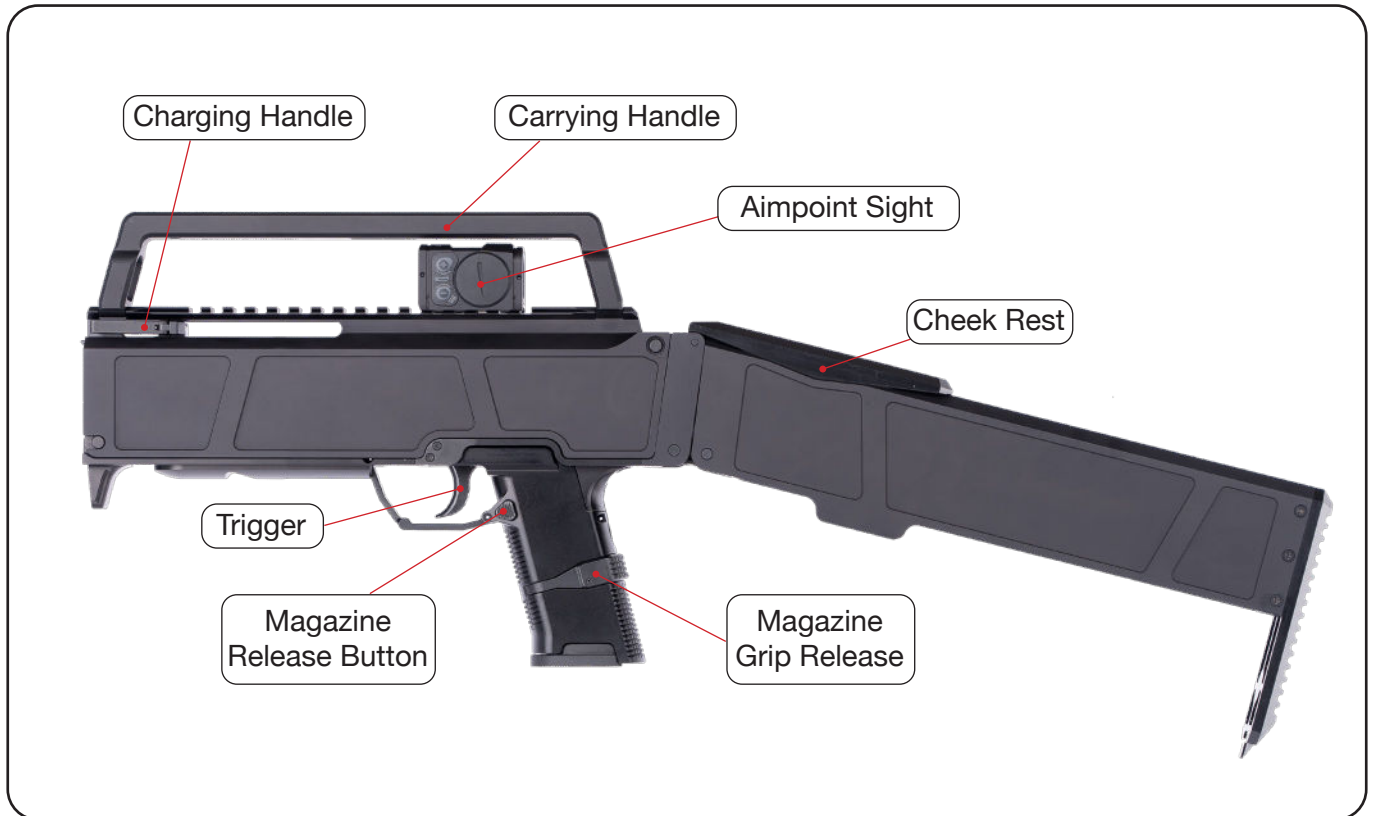

3. Technical data

Designation	B&T BWC9-320	
Manufacturer	B&T AG - Switzerland	
Product ID	BT-430298 (Black) BT-430298-CT (Coyote Tan)	
Width	41 mm	
	Folded	Unfolded
Length	300 mm	565 mm
Height	180 mm	258 mm
Weight	~1.6 kg (without Pistol)	
Interfaces	Aimpoint ® ACRO / NATO Accessory Rail	
Material	Aluminum / Polymer	
Treatment	Hartcoat anodized	
Color	Black Coyote Tan	
Scope of delivery	Chassis complete, Aimpoint ® ACRO	

All product specifications are subject to change without prior notice. Published data are mean values and therefore not suitable acceptance criteria.

4. Installation procedures

4.1 Required tools

The following tools are required to install and/or maintain this B&T product:

- » SIG Sauer P320 operating manual
- » Large flat head screw driver



4.2 Installation

1. Remove the slide and fire control unit from the pistol frame as described in the SIG Sauer P320 manual.



2. Unfold the BWC9 chassis, by holding it at an upward angle and pushing the release button back. The stock and the pistol grip should fold out without resistance. A little swing of the wrist may be required for the stock and pistol grip to lock in their correct positions.



3. Push out the disassembly pin from the left to right. The pin is captured and will not detach completely.

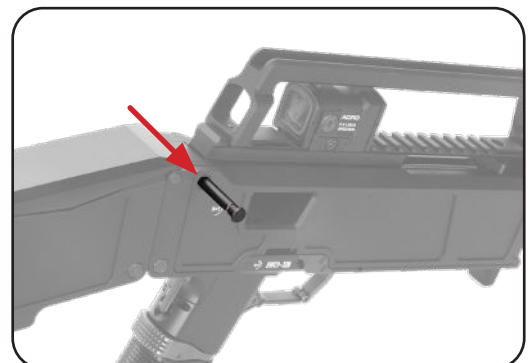

4. Remove the top cover by rotating it upward and lifting it off.



5. Push/Pull the FCU retaining pin out of the chassis.

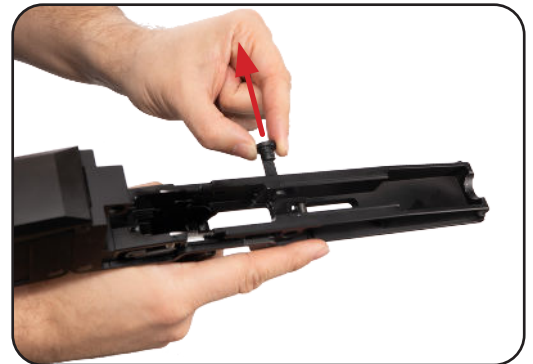

6. Ensure the grip is locked in position, then insert the FCU. Insert the back part first, then swing the front portion down into the chassis. The FCU fits tightly.

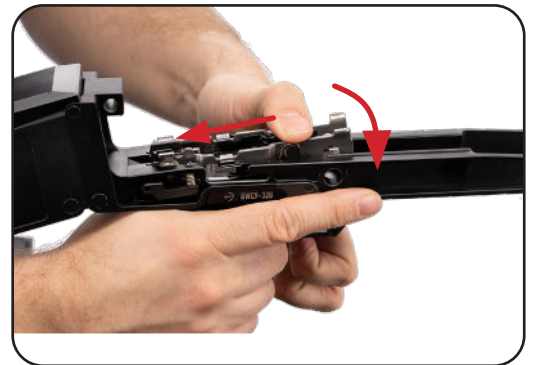

7. Ensure that the FCU is correctly seated in the chassis. The holes for the FCU retaining bolt need to line up with the corresponding holes in the chassis. The top of the FCU should only slightly protrude (~1/2mm) from the upper surface of the chassis.

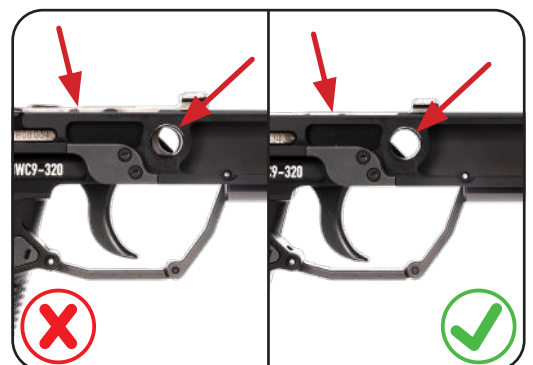

SAFETY ADVICE

Ensure the trigger disconnect is in place as depicted here.

When the grip is unlocked, the disconnect lever must lay parallel to the chassis. Check the function of the trigger disconnect by unlocking the grip and pulling the trigger. With the grip unlocked the sear must not move.

When the grip is in locked, the disconnect lever is being pushed up. It no longer lifts the trigger bar, allowing it to actuate the trigger mechanism. Check the function of the trigger disconnect by unlocking the grip and pulling the trigger. With the grip locked in position the sear should move.



8. Push the FCU retaining pin in from the left side, rotating it to push it past the retaining spring in the FCU.

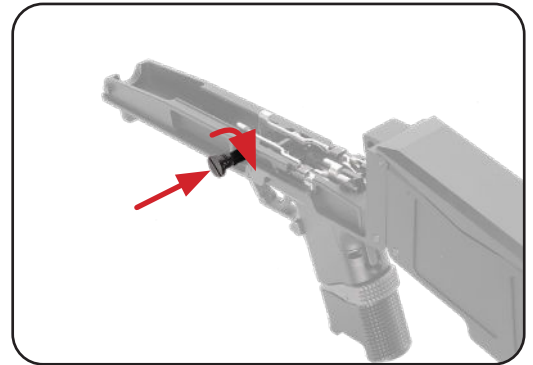

9. To install the barrel and slide, the FCU retaining pin must point to the 4 o'clock position.

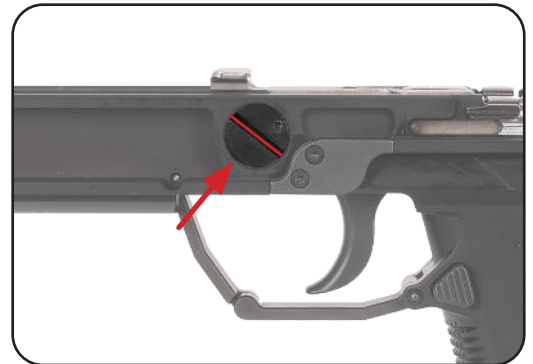

10. Align the barrel and slide assembly with the guide rails in the FCU, pull it back and engage the slide lock.

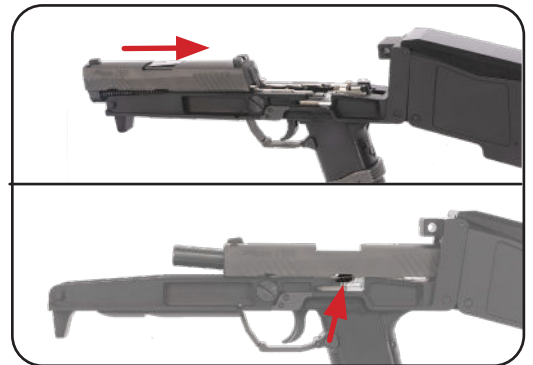

11. With the slide locked back, use a flat head screw driver to rotate the FCU retaining pin counterclockwise until it snaps in place, with the slot roughly vertical.

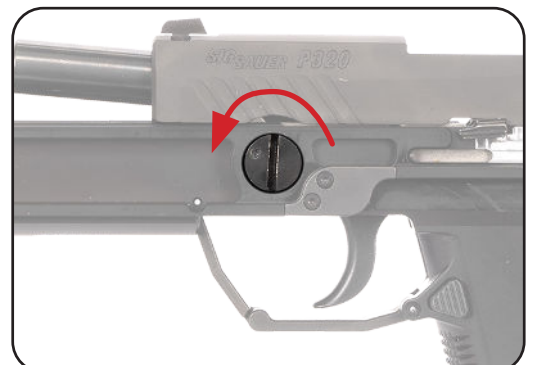

12. If you are using a compact P320 slide, you need to install a spacer behind the charging handle. If you are using a full size slide, skip these steps and continue assembling from step 16.



13. To install the spacer, turn the top cover upside down. Push the brass deflector towards the front against the charging handle return spring. Once the guide rod clears the hole in the top cover it can be tilted out complete with brass deflector and charging handle return spring.

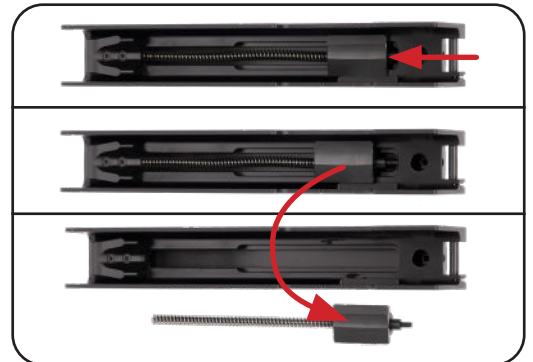

14. The spacer needs to be inserted with the horseshoe shaped protrusion pointing in the muzzle direction.

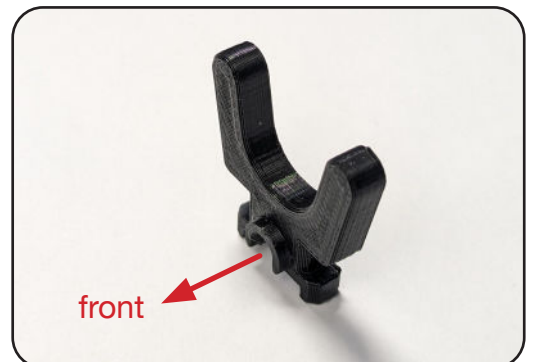

15. Place the spacer in the rails of the top cover and seat it against the loading carriage. Then reinsert the spring, guide rod and brass deflector.

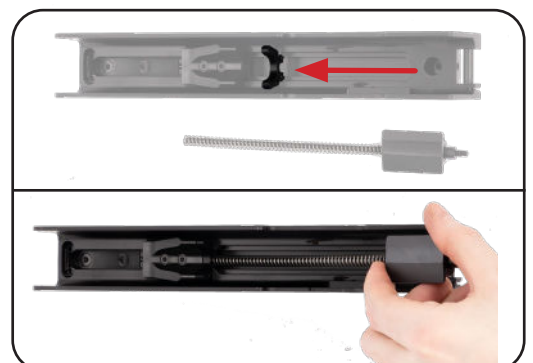

16. Release the slide lock and reattach the top cover, allinging its hooks with the corresponding pegs in the receiver and rotating it down.



17. When the top cover is fully closed, push in the takedown pin until it is flush with the side of the top cover.

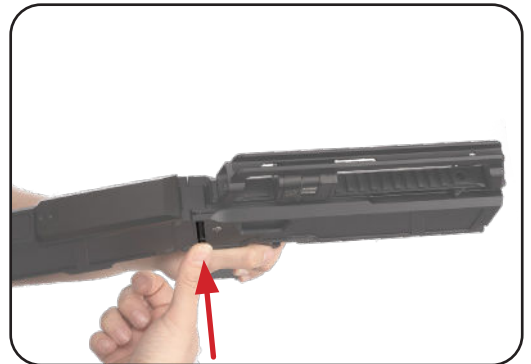

Advice



Perform a Function Check. Cycle the weapon by pulling back the charging handle and letting it go at the end of travel. The slide must fully return into battery.



Disassemble in reverse order

5. Usage

5.1 Folding

SAFETY ADVICE



Make sure there is no round in the chamber!
Remove the magazine by holding the magazine grip release and pushing the magazine release button simultaneously. With the magazine removed, pull back the charging handle and visually inspect the chamber to ensure there is no live ammunition in the weapon.

1. Reinsert the magazine. Push the magazine button without pushing the magazine grip release. The Magazine should stick out about 4 cm/1.5in being caught by the magazine grip release.

2. Unlock the pistol grip by pushing the small lever on the back of the grip. The grip should swing freely.

3. Unlock the shoulder stock by lifting the cheek rest.

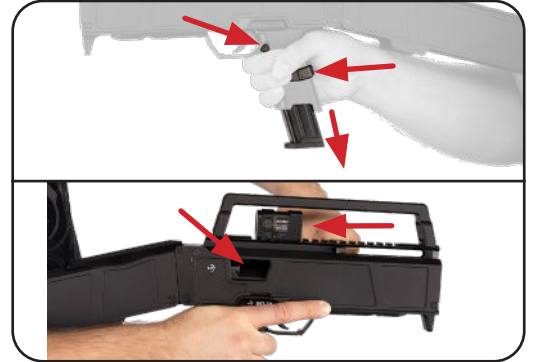

4. Fold the stock down to close the chassis.



5.2 Unfolding

1. Unfold the BWC9 chassis by holding it at an upward angle and pushing the release button back. The stock and pistol grip should fall free. A little flick of the wrist may be required for the stock and pistol grip to lock in their correct positions. Check that the stock and pistol grip are locked in position before proceeding.



2. Fully insert the magazine.



3. Charge the firearm by pulling back the charging handle and letting it go.



6. Maintenance & Troubleshooting

For general maintenance and troubleshooting of your SIG P320, please refer to your pistols owner's manual.



If you are experiencing shifting points of impact or low accuracy please check if your Aimpoint ACRO is properly mounted. Check if the mounting screw is torqued to the specification found in your Aimpoint owner's manual.

For maintenance and troubleshooting of your Aimpoint sight, please also refer to the Aimpoint owner's manual.

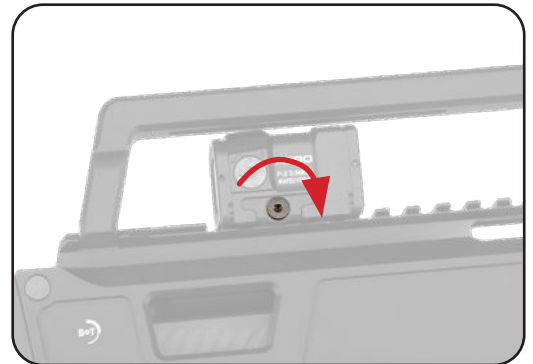

7. Warranty statement

Warranty claims on behalf of the client are to be explicitly declared as such. During the legal warranty period, B&T provides warranty cover solely for defects that arise as a result of faulty materials, construction errors or poor workmanship. If a warranty claim is justified, B&T will, at its own discretion, either repair or replace the defective product. Costs incurred in transporting the defective good to B&T are borne by the client. Spare parts fitted and replaced become the property of B&T.

Inasmuch as is legally permitted, any other liability of B&T is excluded, in particular liability for damages arising either directly or indirectly from the delivered good itself, from its use or from its defects.

Merchandise is covered by the warranty provisions of the manufacturer. Parts that are naturally subject to wear and tear, damage arising from insufficient maintenance work, noncompliance with operating regulations and cases of force majeure are all excluded from warranty cover. Warranty claims lapse if the client itself or third parties alter or repair the delivered good without the prior written consent of B&T. All product specifications are subject to change without prior notice. Published data are mean values and therefore not suitable acceptance criteria.

8. Manufacturer's Disclaimer

The manufacturer is not responsible for improper usage of this product. This product is potentially dangerous, and as such it's the user's responsibility to understand and implement its proper use. If you don't understand the instructions in this manual please contact the manufacturer for further clarification.

The manufacturer:

B&T AG - 3608 Thun - Switzerland

Phone +41 33 334 67 00

e-mail: info@bt-ag.com

Notes:

A large rectangular area filled with a fine grid of small squares, intended for handwritten notes. The grid covers most of the page's central area.

Notes:

A large rectangular area filled with a fine grid of small squares, intended for handwritten notes. The grid covers most of the page's vertical space.

